

# Starting and operating

---

<b>New vehicle break-in driving</b> .....	7-3
<i>The first 1,000 miles (1,600 km)</i> .....	7-3
<b>Fuel requirements</b> .....	7-4
<i>Fuel octane rating</i> .....	7-4
<i>Unleaded gasoline</i> .....	7-4
<i>Gasoline for California-certified LEV and TLEV</i> .....	7-4
<i>Gasoline for cleaner air</i> .....	7-4
<b>State emission testing (U.S. only)</b> .....	7-6
<b>Engine exhaust gas (Carbon monoxide)</b> .....	7-7
<b>Catalytic converter</b> .....	7-8
<b>Fuel economy hints</b> .....	7-9
<b>Preparing to drive</b> .....	7-10
<b>Driving in foreign countries</b> .....	7-10
<b>Periodic inspections</b> .....	7-10
<b>Ignition switch</b> .....	7-11
<b>LOCK</b> .....	7-11
<b>ACC</b> .....	7-12
<b>ON</b> .....	7-12
<b>START</b> .....	7-13
<i>Key reminder chime</i> .....	7-13
<i>Key interlock release (AT vehicles only)</i> .....	7-13
<b>Starting the engine</b> .....	7-14
<i>Manual transmission vehicles</i> .....	7-14
<i>Automatic transmission vehicles</i> .....	7-14
<i>During cold weather below -4° F (-20° C)</i> .....	7-15
<i>Flooded engine</i> .....	7-15
<b>Stopping the engine</b> .....	7-16
<b>Manual transmission</b> .....	7-16
<i>Shifting speed for fuel economy</i> .....	7-17
<i>Maximum speeds</i> .....	7-17
<i>Driving tips</i> .....	7-17
<b>Automatic transmission</b> .....	7-18
<i>Selector lever</i> .....	7-19
<i>Maximum speeds</i> .....	7-21
<i>Driving tips</i> .....	7-21
<i>Shift lock release</i> .....	7-21
<b>Steering</b> .....	7-23
<i>Tilt steering wheel</i> .....	7-23
<i>Power steering</i> .....	7-23

<b>Cruise control (if equipped)</b> .....	<b>7-24</b>
To set cruise control .....	7-24
To temporarily cancel the cruise control .....	7-25
To turn off the cruise control .....	7-25
To change the cruising speed .....	7-25
<b>Parking your vehicle</b> .....	<b>7-26</b>
Parking brake .....	7-26
Parking tips .....	7-27
<b>Tips for using the brakes</b> .....	<b>7-28</b>
Braking tips .....	7-28
Brake system .....	7-29
Disc brake pad wear warning indicators .....	7-30
ABS (Anti-Lock Brake System) (if equipped) .....	7-30
<b>Driving tips for AWD vehicles</b> .....	<b>7-33</b>
<b>Off road driving</b> .....	<b>7-34</b>
All AWD models except OUTBACK .....	7-34
OUTBACK .....	7-35
<b>Winter driving</b> .....	<b>7-37</b>
Operation during cold weather .....	7-37
Driving on snowy and icy roads .....	7-39
Snow tires .....	7-40
Tire chains .....	7-41
Rocking the vehicle .....	7-41
Corrosion protection .....	7-42
<b>Loading your vehicle</b> .....	<b>7-42</b>
Vehicle capacity weight .....	7-43
GVWR and GAWR (Gross Vehicle Weight Rating and Gross Axle Weight Rating) .....	7-43
<b>Trailer towing</b> .....	<b>7-44</b>
Warranties and maintenance .....	7-45
Maximum load limits .....	7-45
Trailer hitches .....	7-46
Trailer lights .....	7-47
Side mirrors .....	7-47
Tires .....	7-47
Trailer towing tips .....	7-48

## New vehicle break-in driving

### ■ The first 1,000 miles (1,600 km)

The performance and long life of your vehicle are dependent on how you handle and care for your vehicle while it is new. Follow these instructions during the first 1,000 miles (1,600 km):

- Do not race the engine.

#### ▼ Break-in engine speed limit

- Vehicle with tachometer

Never exceed 4,000 rpm engine speed except for brief acceleration in an emergency.

- Vehicle without tachometer (for manual transmission)

Do not exceed the speed limits below for each gear position except for brief acceleration in an emergency.

mph (km/h)			
1st	2nd	3rd	4th
20 (30)	30 (50)	50 (80)	65 (105)

- Vehicles without tachometer (for automatic transmission)

Try to drive at moderate speeds while accelerating and braking smoothly. Proper gears are selected automatically according to the driving conditions.

- Do not drive at one constant engine or vehicle speed for a long time, either fast or slow.
- Avoid starting suddenly and rapid acceleration, except in an emergency.
- Avoid hard braking, except in an emergency.

The same break-in procedures should be applied to an overhauled engine, newly mounted engine or when brake pads or brake linings are replaced with new ones.

---

## Fuel requirements

---

### ■ Fuel octane rating

Your engine is designed to use only unleaded gasoline with an octane rating of 87 AKI or higher. This octane rating is the average of the Research Octane and Motor Octane numbers and is commonly referred to as the Anti Knock Index (AKI).

Using a gasoline with a lower octane rating can cause persistent and heavy knocking, which can damage the engine. Do not be concerned if your vehicle sometimes knocks lightly when you drive up a hill or when you accelerate. See your dealer or a qualified service technician if you use a gasoline with the specified octane rating and your vehicle knocks heavily or persistently.

### ■ Unleaded gasoline

The neck of the fuel filler pipe is designed to accept only an unleaded gasoline filler nozzle. Under no circumstances should leaded gasoline be used because it will damage the emission control system and may impair driveability and fuel economy.

### ■ Gasoline for California-certified LEV and TLEV

If your vehicle is a California-certified Low Emission Vehicle (LEV) or Transitional Low Emission Vehicle (TLEV) as indicated on the underhood tune-up label, it is designed to optimize engine and emission control system performance with gasoline that meets California specifications. Your vehicle will operate on gasoline meeting Federal specifications.

### ■ Gasoline for cleaner air



#### **CAUTION**

**Do not let fuel spill on the exterior surfaces of the vehicle. Fuels containing alcohol may cause paint damage, which is not covered under the SUBARU Limited Warranty.**

Your use of gasoline with detergent additives will help prevent deposits from forming in your engine and fuel system. This helps keep your en-

gine in tune and your emission control system working properly, and is a way of doing your part for cleaner air. If you continuously use a high quality fuel with the proper detergent and other additives, you should never need to add any fuel system cleaning agents to your fuel tank.

Many gasolines are now blended with materials called oxygenates. Use of these fuels can also help keep the air cleaner. SUBARU approves the use of oxygenated blend fuels, such as MTBE (Methyl Tertiary Butyl Ether) or ethanol (ethyl or grain alcohol). The blended fuels should contain no more than 15% MTBE or 10% ethanol for the proper operation of your SUBARU.

In addition, some gasoline suppliers are now producing reformulated gasolines, which are designed to reduce vehicle emissions. SUBARU approves the use of reformulated gasoline.

If you are not sure what the fuel contains, you should ask your service station operators if their gasolines contain detergents and oxygenates and if they have been reformulated to reduce vehicle emissions.

As additional guidance, only use fuels suited for your vehicle as explained below.

- Fuel should be unleaded and have an octane rating no lower than that specified in this manual.
- Methanol (methyl or wood alcohol) is sometimes mixed with unleaded gasoline. Methanol can be used in your vehicle **ONLY** if it does not exceed 5% of the fuel mixture **AND** if it is accompanied by sufficient quantities of the proper cosolvents and corrosion inhibitors required to prevent damage to the fuel system. Do not use fuel containing methanol **EXCEPT** under these conditions.
- If undesirable driveability problems are experienced and you suspect they may be fuel related, try a different brand of gasoline before seeking service at your SUBARU dealer.
- Fuel system damage or driveability problems which result from the use of improper fuel are not covered under the SUBARU Limited Warranty.

---

## State emission testing (U.S. only)

---

### **WARNING**

Testing of a Full-Time All Wheel drive vehicle must **NEVER** be performed on a single two-wheel dynamometer. Attempting to do so will result in uncontrolled vehicle movement and may cause an accident or injuries to persons nearby.

### **CAUTION**

Resultant vehicle damage due to improper testing is not covered under the SUBARU Limited Warranty and is the responsibility of the state inspection program or its contractors or licensees.

**At state inspection time, remember to tell your inspection or service station in advance not to place your SUBARU AWD vehicle on a two-wheel dynamometer. Otherwise, serious transmission damage will result.**

Some states have started using dynamometers in their state inspection programs in order to meet their obligation under federal law to implement stricter vehicle emission standards to reduce air pollution from cars. A dynamometer is a treadmill or roller-like testing device that allows your car's wheels to turn while the car remains in one place. Depending on the severity of a state's air pollution problems, the states must adopt either a "basic" or "enhanced" vehicle emission inspection test. Normally, a portion of the basic emission test consists of an emission inspector inserting an analyzer probe into the exhaust pipe of an idling vehicle for a short period of time. States with more severe air pollution problems are required to adopt an enhanced vehicle emission test. This test simulates actual driving conditions on a dynamometer and permits more accurate measurement of tailpipe emitted pollution than the basic emission test.

The U.S. Environmental Protection Agency (EPA) and states using two-wheel dynamometers in their emission testing programs have

**EXEMPTED** SUBARU AWD vehicles from the portion of the testing program that involves a two-wheel dynamometer.

There are some states that use four-wheel dynamometers in their testing programs. When properly used, that equipment will not damage an AWD SUBARU vehicle.

Under no circumstances should the rear wheels be jacked off the ground, nor should the driveshaft be disconnected for state emission testing.

## Engine exhaust gas (Carbon monoxide)

---



### **WARNING**

- **Never inhale engine exhaust gas. Engine exhaust gas contains carbon monoxide, a colorless and odorless gas which is dangerous, or even lethal, if inhaled.**
- **Always properly maintain the engine exhaust system to prevent engine exhaust gas from entering the vehicle.**
- **Never run the engine in a closed space, such as a garage, except for the brief time needed to drive the vehicle in or out of it.**
- **Avoid remaining in a parked vehicle for a lengthy time while the engine is running. If that is unavoidable, then use the ventilation fan to force fresh air into the vehicle.**
- **Always keep the front ventilator inlet grille free from snow, leaves or other obstructions to ensure that the ventilation system always works properly.**
- **If at any time you suspect that exhaust fumes are entering the vehicle, have the problem checked and corrected as soon as possible. If you must drive under these conditions, drive only with all windows fully open.**
- **Keep the trunk lid or rear gate closed while driving to prevent exhaust gas from entering the vehicle.**

---

## NOTE

Due to the expansion and contraction of the metals used in the manufacture of the exhaust system, you may hear a crackling sound coming from the exhaust system for a short time after the engine has been shut off. This sound is normal.

## Catalytic converter

---

### WARNING

- **Avoid fire hazards. Do not drive or park the vehicle anywhere near flammable materials (e.g. grass, paper, rags or leaves), because the catalytic converter operates at very high temperatures.**
- **Keep everyone and flammable materials away from the exhaust pipe while the engine is running. The exhaust gas is very hot.**

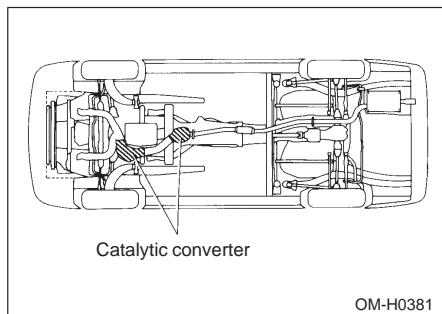

The catalytic converter is installed in the exhaust system. It serves as a catalyst to reduce HC, CO and NO<sub>x</sub> in exhaust gases, thus providing cleaner exhaust.

To avoid damage to the catalytic converter:

- Use only unleaded fuel. Even a small amount of leaded fuel will damage the catalytic converter.
- Never start the engine by pushing or pulling the vehicle.



- Avoid racing the engine.
- Never turn off the ignition switch while the vehicle is moving.
- Keep your engine tuned-up. If you feel the engine running rough (mis-firing, backfiring or incomplete combustion), have your vehicle checked and repaired by an authorized SUBARU dealer.
- Do not apply undercoating or rust prevention treatment to the heat shield of catalytic converter and the exhaust system

## **Fuel economy hints**

---

The following suggestions will help to save your fuel.

- Select the proper gear position for the speed and road conditions.
- Avoid sudden acceleration or deceleration. Always accelerate gently until you reach the desired speed. Then try to maintain that speed for as long as possible.
- Do not pump the accelerator and avoid racing the engine.
- Avoid unnecessary engine idling.
- Keep the engine properly tuned.
- Keep the tires inflated to the correct pressure shown on the tire placard, which is located under the door latch on the driver's side. Low pressure will increase tire wear and fuel consumption.
- Use the air conditioner only when necessary.
- Keep the front and rear wheels in proper alignment.
- Avoid carrying unnecessary luggage or cargo.

---

## Preparing to drive

---

You should perform the following checks and adjustments every day before you start driving.

1. Check that all windows, mirrors, and lights are clean and unobstructed.
2. Check the appearance and condition of the tires. Also check tires for proper inflation.
3. Look under the vehicle for any sign of the leaks.
4. Check that the hood, trunk and rear gate are fully closed.
5. Check the adjustment of the seat.
6. Check the adjustment of the inside and outside mirrors.
7. Fasten your seat belt. Check that your passengers have fastened their seat belts.
8. Check the operation of the warning and indicator lights when the ignition switch is turned to the "ON" position.
9. Check the gauges, indicator and warning lights after starting the engine.

### NOTE

Engine oil, engine coolant, brake fluid, washer fluid and other fluid levels should be checked daily, weekly or at fuel stops.

---

## Driving in foreign countries

---

When planning to use your vehicle in another country:

- Confirm the availability of the correct fuel. (Refer to Fuel Requirement section in this chapter.)
- Comply with all regulations and requirements of each country.

---

## Periodic inspections

---

To keep your vehicle in the best condition at all times, always have the recommended maintenance services listed in the maintenance schedule in the Warranty and Maintenance Booklet performed at the specified time or mileage intervals.

## Ignition switch



### **WARNING**

Never turn the ignition switch to “LOCK” while the vehicle is being driven or towed because that will lock the steering wheel, preventing steering control. And when the engine is turned off, it takes a much greater effort than usual to steer.

The ignition switch has four positions: LOCK, ACC, ON and START.

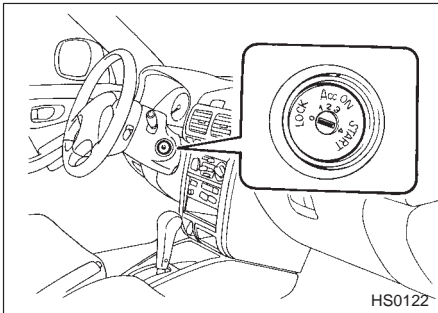

### ■ LOCK

The key can only be inserted or removed in this position. The ignition switch will lock the steering wheel when you remove the key.

If turning the key is difficult, turn the steering wheel slightly to the right and left as you turn the key.

## ▼ Automatic transmission vehicles

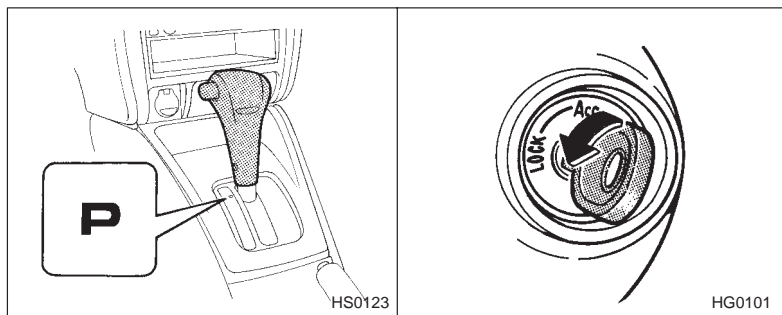

The key can be turned from “ACC” to “LOCK” only when the selector lever is in the “P” position.

## ▼ Manual transmission vehicles

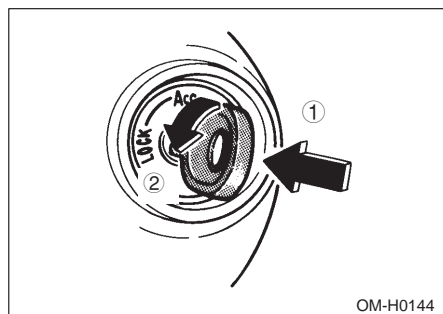

The key can be turned from “ACC” to “LOCK” only when the key is pushed in while turning it.

### ■ ACC

In this position the electrical accessories (radio, accessory socket, etc.) can be used.

### ■ ON

This is the normal operating position after the engine is started.

## ■ START



### CAUTION

Do not turn the ignition switch to the “START” position while the engine is running.

The engine is started in this position. The starter cranks the engine to start it. When the key is released (after the engine has started), the key automatically returns to the “ON” position.

### ■ Key reminder chime

The reminder chime sounds when the driver’s door opens and the key is in the “LOCK” or “ACC” positions. The chime stops when the key is removed from the ignition switch.

### ■ Key interlock release (AT vehicles only)

If the key can not be turned to the “LOCK” position even when the selector lever is in the “P” position:

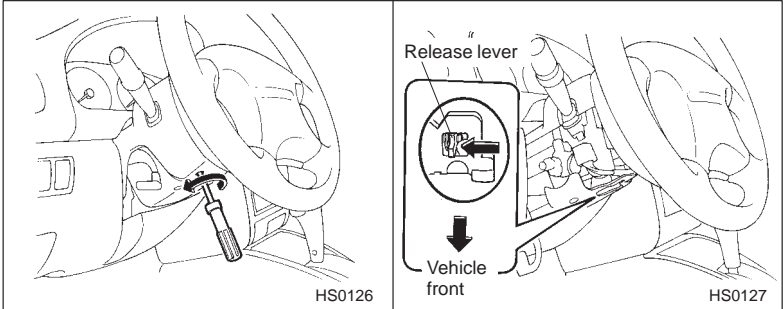

1. Take out the screwdriver from the tool bag.
2. Remove three screws securing the undercover of the steering column.
3. Remove the undercover of the steering column.
4. Turn the ignition key while pressing the key interlock release lever.

Take your vehicle to the nearest SUBARU dealer immediately to have the key interlock system repaired.

---

## Starting the engine

---

### CAUTION

**Do not operate the starter motor continuously for more than ten seconds. If the engine fails to start after operating the starter for five to ten seconds, wait for ten seconds or more before trying again.**

#### ■ Manual transmission vehicles

1. Apply the parking brake.
2. Turn off unnecessary lights and accessories.
3. Press the clutch pedal to the floor and shift the shift lever into neutral. Hold the clutch pedal to the floor while starting the engine. The starter motor will only operate when the clutch pedal is pressed fully to the floor.
4. Turn the ignition switch to the “ON” position and check the operation of the warning and indicator lights. Refer to Warning and Indicator Lights section (chapter 3).
5. Turn the ignition switch to the “START” position without depressing the accelerator pedal. Release the key immediately after the engine has started.

If the engine does not start within ten seconds, wait a while and then turn the ignition switch to the “START” position again while depressing the accelerator pedal half way down.

6. Confirm that all warning and indicator lights have gone off after the engine has started. The fuel injection system automatically lowers the idle speed as the engine warms up.

#### ■ Automatic transmission vehicles

### CAUTION

**If you restart the engine while the vehicle is moving, shift the selector lever into the “N” position. Do not attempt to place the selector lever of a moving vehicle into the “P” position.**

1. Apply the parking brake.
2. Turn off unnecessary lights and accessories.
3. Shift the selector lever to the “P” or “N” position (preferably “P” position).

The starter will only operate when the select lever is at the “P” or “N” position.

4. Turn the ignition switch to the “ON” position and check the operation of the warning and indicator lights. Refer to Warning and Indicator Lights section (chapter 3).
5. Turn the ignition switch to the “START” position **without depressing the accelerator pedal**. Release the key immediately after the engine has started.

If the engine does not start within ten seconds, wait a while and then turn the ignition switch to the “START” position again while depressing the accelerator pedal half way down.

6. Confirm that all warning and indicator lights have gone out after the engine has started. The fuel injection system automatically lowers the idle speed as the engine warms up.

While the engine is warming up, make sure that the selector lever is at the “P” or “N” position and that the parking brake is applied.

#### ■ **During cold weather below $-4^{\circ}\text{F}$ ( $-20^{\circ}\text{C}$ )**

If the engine is difficult to start using the normal method (without depressing the accelerator pedal), turn the ignition switch to the “START” position while slightly depressing the accelerator pedal.

#### ■ **Flooded engine**

If the engine does not start, it may be flooded (excessive fuel in the engine).

In case of a flooded engine, turn the starter motor for five seconds with the accelerator pedal fully depressed. Repeat this two or three times until the engine starts. Release the ignition switch and accelerator pedal as soon as the engine starts.

---

## Stopping the engine

---

### **WARNING**

Do not stop the engine when the vehicle is moving. This will cause loss of power to the power steering and the brake booster, making steering and braking more difficult. It could also result in accidental activation of the “LOCK” position on the ignition switch, causing the steering wheel to lock.

The ignition switch should be turned off only when the engine is idling.

## Manual transmission

---

### **CAUTION**

Shift into reverse **ONLY** when the vehicle has completely stopped. It may cause damage to the transmission to try shifting into reverse when the vehicle is moving.

The manual transmission is a fully synchromeshed 5-forward and 1-reverse speed transmission.

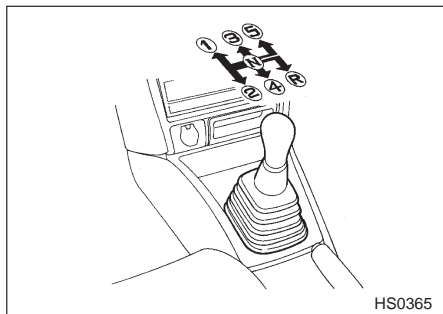

The shift pattern is shown on the shift lever knob. When shifting from 5th gear to reverse gear, first return the shift lever to neutral position then



shift into the reverse gear.

To change gears, fully depress the clutch pedal, move the shift lever, and gradually let the pedal up.

### ■ Shifting speed for fuel economy

The best compromise between fuel economy and vehicle performance during normal driving is ensured by shifting up at the speeds listed in the following table.

Shift up	mph (km/h)
1st to 2nd	15 (24)
2nd to 3rd	25 (40)
3rd to 4th	40 (65)
4th to 5th	45 (73)

### ■ Maximum speeds

#### ▼ Vehicle with tachometer

Never drive with the tachometer needle in the critical engine speed range except for brief acceleration in an emergency.

#### ▼ Vehicle without tachometer

Never exceed the speed limits below for each gear position except for brief acceleration in an emergency.

mph (km/h)		
1st	2nd	3rd
28 (45)	50 (80)	70 (115)

### ■ Driving tips

Do not drive with your foot resting on the clutch pedal and do not use the clutch to hold your vehicle at standstill on an upgrade. Either of those

– CONTINUED –

---

actions may cause clutch damage.

Do not drive with your hand resting on the shift lever. This may cause wear on the transmission components.

When it is necessary to reduce vehicle speed due to slow traffic, turning corners, or driving up steep hills, downshift to a lower gear before the engine starts to labor.

On steep downgrades, downshift the transmission to 4th, 3rd or 2nd gear as necessary; this helps to maintain a safe speed and to extend brake pad life.

In this way, the engine provides a braking effect. Remember, if you “ride” (over use) the brakes while descending a hill, they may overheat and not work properly.

## Automatic transmission

---

### **WARNING**

Do not shift from the “P” or “N” position into the “D”, “3”, “2”, “1” or “R” position while depressing the accelerator pedal. This may cause the vehicle to jump forward or backward.

### **CAUTION**

- Shift into the “P” or “R” position only after the vehicle is completely stopped. Shifting while the vehicle is moving may cause damage to the transmission.
- Do not race the engine for more than five seconds in any position except the “N” or “P” position when the brake is set or the tires are on blocks. This may cause the automatic transmission fluid to overheat.
- Avoid shifting from one of the forward driving positions into the “R” position or vice versa until the vehicle has completely stopped. Such a shifting may cause damage to the transmission.

The automatic transmission is an electronically controlled with 4-forward speeds and 1-reverse speed.

### ■ Selector lever

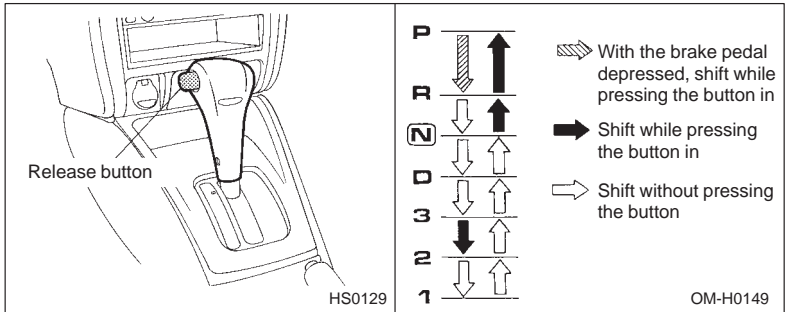

The selector lever has seven positions.

The release button must be pushed to select the “P”, “R”, or “2” positions.

#### ▼ P (Park)

This position is for parking the vehicle and starting the engine.

In this position, the transmission is mechanically locked to prevent the vehicle from rolling freely.

When you park the vehicle, first set the parking brake fully, then shift into the “P” position. Do not hold the vehicle only with the transmission.

The shift interlock function is employed in this automatic transmission system to ensure safety of starting the vehicle.

To shift the selector lever from the “P” to the any other position, you have to depress the brake pedal fully then push the release button on the selector lever when the ignition switch is in the “ON” position. This prevents the vehicle from lurching off when starting.

If the shift lever should not move from the “P” position with the brake pedal depressed and the release button pushed in when the ignition

– CONTINUED –

---

switch is in the “ON” position, refer to Releasing shift interlock in this chapter.

### ▼ R (Reverse)

This position is for backing the vehicle.

To shift from the “N” to “R” position, first stop the vehicle completely then move the lever to the “R” position while pushing the release button.

### ▼ N (Neutral)

This position is for restarting a stalled engine.

In this position the wheels and transmission are not locked. In this position, the transmission is neutral; the vehicle will roll freely, even on the slightest incline unless the parking brake or brakes are on.

Avoid coasting with the transmission neutral. During coasting, the engine braking does not act.

### ▼ D (Drive)

This position is for normal driving.

The transmission automatically shifts into a suitable gear from 1st to 4th according to the vehicle speed and the acceleration you require.

When more acceleration is required in this position, press the accelerator pedal fully to the floor and hold that position. The transmission will automatically downshift to 3rd, 2nd or 1st gear. When you release the pedal, the transmission will return to the original gear position.

### ▼ 3 (Third)

This position is for using engine braking when going down a hill or for climbing a grade.

The transmission automatically shifts into a suitable gear from 1st to 3rd according to the vehicle speed and the acceleration you require.

When more acceleration is required in this position, press the accelerator pedal fully to the floor and hold that position. The transmission will automatically downshift to 2nd or 1st gear. When you release the pedal, the transmission will return to the original gear position.

### ▼ 2 (Second)

To shift from the “3” position, push the release button.

This position is for using engine braking when going down a hill or for climbing a steep grade.

In this position, the transmission holds in the 2nd gear.

Use this position when starting off from a standstill on slippery road surfaces such as mud or snow. It will ensure greater traction.

### ▼ 1 (First)

This position is for driving up or down very steep grades, or driving through mud or sand, or on slippery surfaces. In this position, the transmission holds in the 1st gear.

## ■ Maximum speeds

Never drive with the tachometer needle in the critical engine speed range except for brief acceleration in an emergency.

## ■ Driving tips

- Always apply the foot or parking brake when the vehicle is stopped in the “D”, “3”, “2”, “1”, or “R” position.
- Always set the parking brake when parking your vehicle. Do not hold the vehicle only with the transmission.
- Do not keep the vehicle in a stationary position on an uphill grade by using the “D”, “3”, “2” or “1” position. Use the brake instead.

## ■ Shift lock release

If the selector lever does not move from the “P” position with the brake pedal depressed and the release button pushed in, perform the following steps:

To override the shift lock:

1. Set the parking brake and stop the engine.

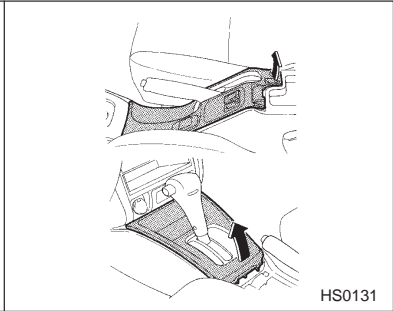
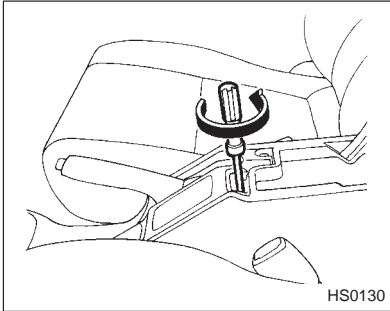

2. Take out the screwdriver from the tool bag.
3. Open the center console and remove two screws securing the parking brake lever cover.
4. Remove the parking brake lever cover by pulling up on the cover's rear end.
5. Raise the rear end of the selector lever cover.

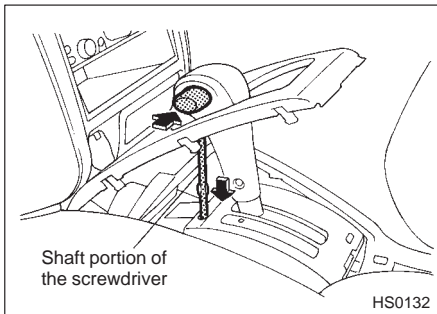

6. Draw the shaft portion of the screwdriver from the grip and then insert the shaft into the hole.
7. Push down on the shaft while pushing the release button and move the selector lever from the "P" to the "N" position.
8. Remove the shaft from the hole. Depress the brake pedal and start the engine.

Take your vehicle to the nearest SUBARU dealer immediately to have the system repaired.

## Steering

### ■ Tilt steering wheel



#### **WARNING**

Do not adjust the steering tilt position while driving. This may cause loss of vehicle control and result in personal injury.

#### ▼ Tilt adjustment

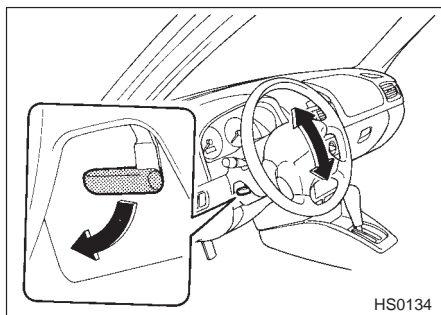

1. Adjust the seat position. Refer to Front Seat section (chapter 2).
2. Pull the tilt lock lever down.
3. Move the steering wheel to the desired level.
4. Push the lever up to lock the steering wheel in place.
5. Make sure that the steering wheel is securely locked by moving it up and down.

### ■ Power steering



#### **CAUTION**

Do not hold the steering wheel at the fully locked position left or right for more than five seconds. This may damage the power steering pump.

The power steering system operates only when the engine is running.

– CONTINUED –

If you lose power steering assist because the engine stops or the system fails to function, you can steer but it will take much more effort.

## Cruise control (if equipped)

### **WARNING**

**Do not use the cruise control under any of the following conditions. This may cause loss of vehicle control:**

- driving up or down a steep grade
- driving on slippery or winding roads
- driving in heavy traffic

Cruise control enables you to maintain a constant vehicle speed without holding your foot on the accelerator pedal and it is operative when the vehicle speed is 25 mph (40 km/h) or more.

Make sure the main switch is turned “OFF” when the cruise control is not in use to avoid unintentional cruise setting.

### ■ To set cruise control

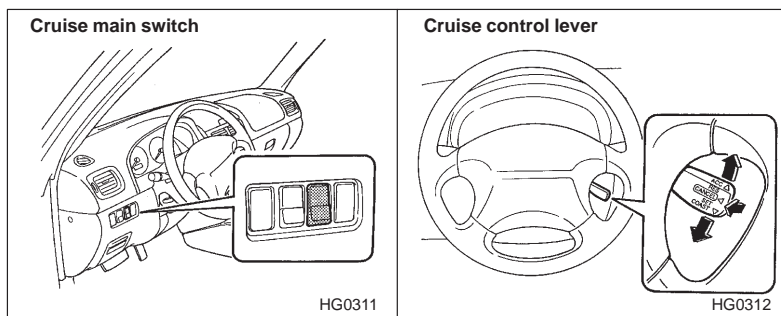

1. Push the “CRUISE” main switch.
2. Depress the accelerator pedal until the vehicle reaches to the desired speed.
3. Push the control lever downward in the “SET, COAST” direction and release it. Then release the accelerator pedal.



The vehicle will maintain the desired speed.

Vehicle speed can be temporarily increased while driving with the cruise control activated. Simply depress the accelerator pedal to accelerate the vehicle. When the accelerator pedal is released, the vehicle will return to and maintain the previous cruising speed.

### ■ **To temporarily cancel the cruise control**

There are four ways to cancel the cruise control temporarily:

- Depress the brake pedal.
- Pull the control lever in the “CANCEL” direction.
- Depress the clutch pedal (manual transmission vehicles only).
- Shift the selector lever into the “N” position (automatic transmission vehicles only).

To resume the cruise control after it has been temporarily canceled and with vehicle speed of 25 mph (40 km/h) or more, push the control lever upward in the “ACCEL, RESUME” direction to return to the original cruising speed automatically.

### ■ **To turn off the cruise control**

There are two ways to turn off the cruise control:

- Push the main switch again.
- Turn the ignition switch to the “ACC” position (but only when the vehicle is completely stopped).

### ■ **To change the cruising speed**

#### ▼ **To increase the speed**

1. Push the control lever upward in the “ACCEL, RESUME” direction and hold it until the vehicle reaches the desired speed.

The control lever can be used for increasing the cruising speed slightly. Pressing the control lever upward in the “ACCEL, RESUME” direction increases the vehicle speed about 1 mph (1.6 km/h). Press the control lever repeatedly until the desired speed is reached.

**OR**

1. Depress the accelerator pedal to accelerate the vehicle to the de-

– **CONTINUED**–

---

sired speed.

2. Push the control lever downward in the “SET, COAST” direction once. Now the desired speed is set and the vehicle will keep running at that speed without depressing the accelerator pedal.

#### ▼ To decrease the speed

1. Push the control lever downward in the “SET, COAST” direction and hold it until the vehicle reaches the desired speed.

The control lever can be used for decreasing the cruising speed slightly. Pressing the control lever downward in the “SET, COAST” direction decreases the vehicle speed about 1 mph (1.6 km/h). Press the control lever repeatedly until the desired speed is reached.

#### OR

1. Depress the brake pedal to release cruise control temporarily.
2. When the speed decreases to the desired speed, press the control lever downward in the “SET, COAST” direction once. Now the desired speed is set and the vehicle will keep running at that speed without depressing the accelerator pedal.

## Parking your vehicle

---

### ■ Parking brake



#### **CAUTION**

**Never drive while the parking brake is set because this will cause unnecessary wear on the brake linings. Before starting to drive, always make sure that the parking brake has been fully released.**

To set the parking brake, press the brake pedal firmly and hold it down while fully pulling up the parking brake lever.

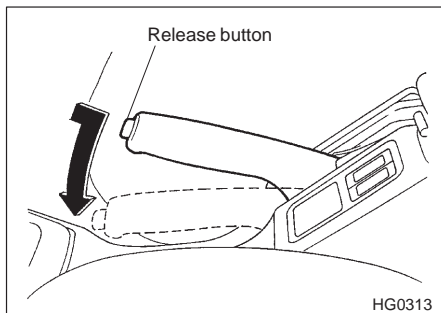

To release the parking brake, pull the lever up slightly, press the release button, then lower the lever while keeping the button pressed.

When the parking brake is set while the engine is running, the parking brake warning light comes on. After starting the vehicle, be sure that the warning light has gone out before the vehicle is driven. Refer to Warning and Indicator Lights section (chapter 3).

### ■ Parking tips



#### **WARNING**

- **Never leave unattended children or pets in the vehicle. They could accidentally injure themselves or others through inadvertent operation of the vehicle. Also, on hot or sunny days, the temperature in a closed vehicle could quickly become high enough to cause severe or possibly fatal injuries to them.**
- **Do not park the vehicle over flammable materials such as dry grass, waste paper or rags, as they may burn easily if they come near hot engine or exhaust system parts.**
- **Always stop the engine if you take a nap in the vehicle. If engine exhaust gas enters the passenger compartment, occupants in the vehicle could die from carbon monoxide (CO) contained in the exhaust gas.**

---

When parking your vehicle, always set the parking brake firmly and put the shift lever in the “1” (1st) for an upgrade or “R” (Reverse) for a down grade for manual transmission vehicles, or in the “P” (Park) position for automatic transmission vehicles.

Always set the parking brake firmly when parking your vehicle. Never rely on the transmission alone to hold the vehicle.

For better parking brake power, depress the brake pedal firmly while setting the parking brake.

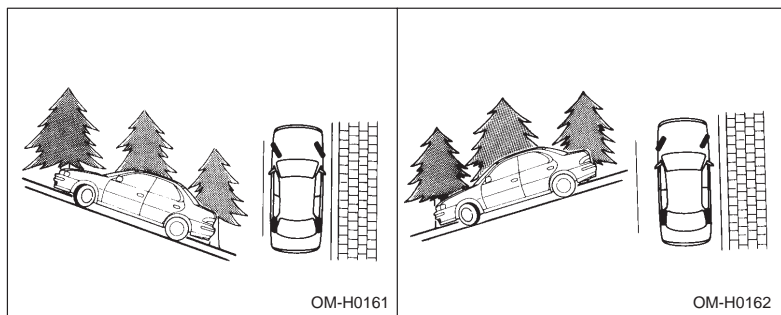

When parking on a hill, always turn the steering wheel. When the vehicle is headed up the hill, the front wheels should be turned away from the curb. When facing down hill, the front wheels should be turned into the curb.

## Tips for using the brakes

---

### ■ Braking tips

#### **WARNING**

**Never rest your foot on the brake pedal while driving. This can cause dangerous overheating of the brakes and needless wear on the brake pads and linings.**

▼ **When the brakes get wet**

When driving in rain, in puddle or after washing the vehicle, the brakes may get wet. As a result, brake stopping distance will be longer. To dry the brakes, drive the vehicle at a safe speed while lightly depressing the brake pedal to heat up the brakes.

▼ **Use of engine braking**

Remember to make use of engine braking in addition to foot braking. When descending a grade, if only the foot brake is used, the brakes may start working improperly because of brake fluid overheating, caused by overheated brake pads. To help prevent this, shift into a lower gear to get stronger engine braking.

▼ **Braking when a tire is punctured**

Do not depress the brake pedal suddenly when a tire is punctured. This could cause a loss of control of the vehicle. Keep driving straight ahead while gradually reducing speed. Then slowly pull off the road to a safe place.

■ **Brake system**

▼ **Two separate circuits**

Your vehicle has two separate circuit brake systems. Each circuit works diagonally across the vehicle. If one circuit of the brake system should fail, the other half of the system still works. If one circuit fails, the brake pedal will go down much closer to the floor than usual and you need to press it down much harder. And a much longer distance will be needed to stop the vehicle.

▼ **Brake booster**

The brake booster uses engine manifold vacuum to assist braking force. Do not turn off the engine while driving because that will turn off the brake booster, resulting in poor braking power.

The brakes will continue to work even when the brake booster completely stops functioning. If this happens, however, you will have to push the pedal much harder than normal and the braking distance will increase.

## ■ Disc brake pad wear warning indicators

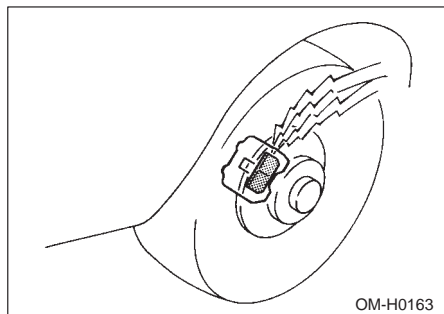

The disc brake pad wear warning indicators on the disc brakes give a warning noise when the brake pads are worn.

If a squeaking or scraping noise is heard from the disc brakes while braking, immediately have your vehicle checked by your SUBARU dealer.

## ■ ABS (Anti-Lock Brake System) (if equipped)

### **WARNING**

Always use the utmost care in driving – overconfidence because you are driving with an ABS equipped vehicle could easily lead to a serious accident.

### **CAUTION**

- The ABS system cannot always decrease stopping distance. Therefore always maintain a safe distance from the vehicle in front of you.
- When driving on badly surfaced roads, gravel roads, icy roads, or over deep newly fallen snow, stopping distances may be longer for a vehicle with the ABS system than one without. When driving under these conditions, therefore, reduce your speed and leave ample distance from other vehicles.

- **When you feel the ABS system operating, you should maintain constant brake pedal pressure. Do not pump the brake pedal since doing so may defeat the operation of the ABS system.**

The ABS system prevents the lock-up of wheels which may occur during sudden braking or braking on slippery road surfaces. This helps prevent the loss of steering control and directional stability caused by wheel lock-up.

When the ABS system is operating, you may hear a chattering noise or feel a slight vibration in the brake pedal. This is normal when the ABS operates.

The ABS system will not operate when the vehicle speed is below approximately 6 mph (10 km/h).

#### ▼ **ABS system self-checking**

You may feel a slight shock in the brake pedal and hear the operating sound of ABS from the engine compartment just after the vehicle started. These are caused by an automatic functional test of the ABS system being carried out and does not indicate any abnormal condition.

#### ▼ **ABS warning light**

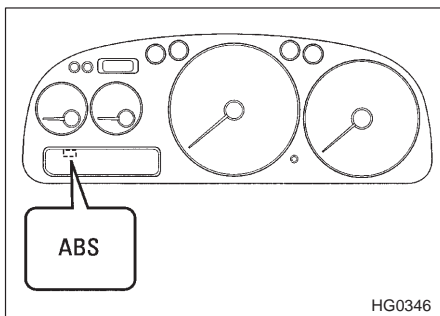

The ABS warning light comes on when the ignition switch is turned to the "ON" position and goes out after about two seconds.

This is an indication that the ABS system is working properly.

– **CONTINUED**–

---

If the warning light behaves as follows, ABS system may not work properly.

- The warning light does not come on when the ignition switch is turned to the "ON" position.
- The warning light comes on when the ignition switch is turned to the "ON" position, but it does not go out even when the vehicle speed exceeds approximately 8mph (12km/h).
- The warning light comes on during driving.

When the warning light is on, the ABS function shuts down; however, the conventional brake system continues to operate normally. If this occurs, have the ABS system repaired at the first available opportunity by your SUBARU dealer.

#### **NOTE**

If the warning light behavior is as shown below, the ABS system may be considered normal.

- The warning light comes on right after the engine is started but goes out immediately, remaining off.
- The warning light remains on after the engine has been started, but it goes out when the vehicle speed reaches about 8 mph (12 km/h).
- The warning light comes on during driving, but it goes out immediately and remains off.

When driving with an insufficient battery voltage such as when the engine is jump started, the ABS warning light may come on. This is due to the low battery voltage and does not indicate a malfunction. When the battery becomes fully charged, the light will go out.



## Driving tips for AWD vehicles

### **WARNING**

- Always maintain a safe driving speed according to the road and weather conditions in order to avoid having an accident on a sharp turn, during sudden braking or under other similar conditions.
- Always use the utmost care in driving – overconfidence because you are driving an all wheel drive vehicle could easily lead to a serious accident.

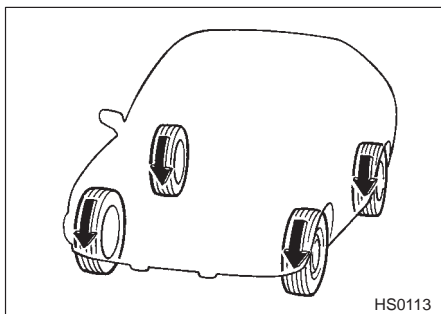

All wheel drive distributes the engine power to all four wheels. AWD vehicles provide better traction when driving on slippery, wet or snow-covered roads and when moving out of mud, dirt and sand. By shifting power between the front and rear wheels, SUBARU AWD can also provide added traction during acceleration and added engine braking force during deceleration.

Therefore, your SUBARU AWD vehicle may handle differently than an ordinary two wheel drive vehicle and it contains some features unique to AWD. For safety purposes as well as to avoid damaging the AWD system, you should keep the following tips in mind:

- An AWD vehicle is better able to climb steeper roads under snowy or slippery conditions than a two wheel drive vehicle. There is little differ-

– **CONTINUED**–

---

ence in handling, however, during extremely sharp turns or sudden braking. Therefore, when driving down a slope or turning corners, be sure to reduce your speed and maintain an ample distance from other vehicles.

- When replacing a tire, make sure you use only the same size, construction, brand, and load range as the original tires listed on the tire placard. Using other sizes or construction may result in severe mechanical damage to the drive train of your vehicle and may affect ride, handling, braking, speedometer/odometer calibration, and clearance between the body and tires. It also may be dangerous and lead to loss of vehicle control.
- If you use a temporary spare tire to replace a flat tire, be sure to use the original temporary spare tire stored in the vehicle. Using other sizes may result in severe mechanical damage to the drive train of your vehicle.
- Always check the cold tire pressure before starting to drive. The recommended tire pressure is provided on the tire placard, which is located under the door latch on the driver's side.
- Tire chains should always be placed on the front wheels only.
- There are some precautions that you must observe when towing your vehicle. For detail information, see the Towing section in chapter 8.

## Off road driving

---



### **WARNING**

- **Always maintain a safe driving speed according to the road and weather conditions in order to avoid having an accident on a sharp turn, during sudden braking or under other similar conditions.**
- **Always use the utmost care in driving – overconfidence because you are driving an all wheel drive vehicle could easily lead to a serious accident.**

### **■ All AWD models except OUTBACK**

Your AWD vehicle is neither a conventional off-road vehicle nor an all terrain vehicle. It is a passenger car designed primarily for on-road use. The AWD feature gives it some limited off-road capabilities in situation in

which driving surfaces a relatively level, obstruction-free and otherwise similar to on-road driving conditions. Operating it under other than those conditions could subject the vehicle to excessive stress which might result in damage not eligible for repair under warranty. If you do take your SUBARU off road, you should review the common sense precautions in the next section (applicable to the OUTBACK) for general guidance. But please keep in mind that your vehicle's off-road capabilities are more limited than those of the OUTBACK.

## ■ OUTBACK

Because of the AWD feature and higher ground clearance, your Subaru can be driven on ordinary roads or off-road. But please keep in mind that an AWD Subaru is a passenger car and is neither a conventional off-road vehicle nor an all-terrain vehicle. If you do take your Subaru off-road, certain common sense precautions such as the following should be taken:

- Make certain that you and all of your passengers are wearing seat belts.
- Carry some emergency equipment, such as a towing rope or chain, a shovel, wheel blocks, first aid kit and portable phone or citizens band radio.
- Drive carefully. Do not take unnecessary risks by driving in dangerous areas or over rough terrain.
- Slow down and employ extra caution at all times. When driving off-road, you will not have the benefit of marked traffic lanes, banked curves, traffic signs and the like.
- Do not drive across steep slopes. Instead, drive either straight up or straight down the slopes. A vehicle can much more easily tip over sideways than it can when moving forward or backward. Avoid driving straight up or down slopes that are too steep.
- Avoid sharp turning maneuvers, especially at higher speeds.
- Do not grip the inside or spokes of the steering wheel. A bad bump could jerk the wheel and injure your hands. Instead drive with your fingers and thumbs on the outside of the rim.
- If driving through water, such as when crossing shallow streams, first check the depth of the water and the bottom of the stream bed for firm-

– CONTINUED–

---

ness and ensure that the bed of the stream is flat. Drive slowly and completely through the stream. The water should be shallow enough that it does not reach the vehicle's undercarriage. Water entering the engine air intake or the exhaust pipe or water splashing onto electrical parts may damage your vehicle and may cause it to stall. Never attempt to drive through rushing water; regardless of its depth, it can wash away the ground from under your tires, resulting in possible loss of traction and even vehicle rollover.

- Always check your brakes for effectiveness immediately after driving in sand, mud or water. Do this by driving slowly and stepping on the brake pedal. Repeat that process several times to dry out the brake discs and brake pads.
- Do not drive or park over or near flammable materials such as dry grass or fallen leaves, as they may burn easily. The exhaust system is very hot while engine is running and right after engine stops. This could create a fire hazard.
- After driving through tall grass, mud, rock, sand, rivers, etc., check that there is no grass, bush, paper, rags, stones, sand, etc. adhering to or trapped on the underbody. Clear off any such matter from the underbody. If the vehicle is used with these materials trapped or adhering to the underbody, a mechanical breakdown or fire could occur.
- Secure all cargo carried inside the vehicle and make certain that it is not piled higher than the seatbacks. During sudden stops or jolts, unsecured cargo could be thrown around in the vehicle and cause injury. Do not pile heavy loads on the roof. Those loads raise the vehicle's center of gravity and make it more prone to tip over.
- If you must rock the vehicle to free it from sand or mud, depress the accelerator pedal slightly and move the selector lever back and forth between "D" and "R" repeatedly. Do not race the engine. For the best possible traction, avoid spinning the wheels when trying to free the vehicle. When the road surface is extremely slippery, you can obtain better traction by starting the vehicle with the transmission in 2nd than 1st (both for MT and AT).
- Never equip your vehicle with tires larger than those specified in this manual.
- Frequent driving of an AWD vehicle under hard-driving conditions such

as rough roads or off roads will necessitate more frequent replacement of engine oil, brake fluid and transmission oil than that specified in the maintenance schedule described in the Warranty and Maintenance Booklet.

Remember that damage done to your Subaru while operating if off-road and not using common sense precautions such as those listed above is not eligible for warranty coverage.

## Winter driving

---

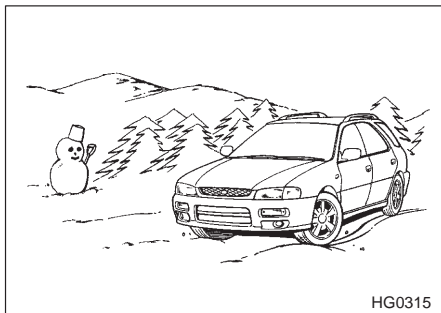

### ■ Operation during cold weather

Carry some emergency equipment, such as tire chains, a window scraper, a bag of sand, flares, a small shovel, and jumper cables.

Check the battery and cables. Cold temperatures reduce battery capacity. The battery must be in good condition to provide enough power for cold winter starts.

Use an engine oil of proper grade and viscosity for cold weather. Heavy summer oil will cause harder starting.

Keep the door locks from freezing by squirting them with deicer or glycerin.

Forcing a frozen door open may damage or separate the rubber weather strips around the door. If the door is frozen, use hot water to melt the ice, and afterwards thoroughly wipe the water away.

– CONTINUED–

---

Use a windshield washer fluid that contains an antifreeze solution. Do not use engine antifreeze or other substitutes because they may damage the paint of the vehicle.

### ▼ Before driving your vehicle

Before entering the vehicle, remove any snow or ice from your shoes because that could make the pedals slippery and dangerous.

While warming up the vehicle before driving, check that the accelerator pedal, brake pedal, and all other controls operate smoothly.

Clear away ice and snow that has accumulated under the fenders to avoid making steering difficult. During severe winter driving, stop when and where it is safe to do so and check under the fenders periodically.

### ▼ Parking in cold weather



## **WARNING**

**Snow can trap dangerous exhaust gases under your vehicle. Keep snow clear of the exhaust pipe and from around your vehicle if you park the vehicle in snow with the engine running.**

Do not use the parking brake when parking for long periods in cold weather since it could freeze in that position. Instead, observe the following:

1. Place the shift lever in “1” or “R” for manual transmission vehicles, and in “P” for automatic transmission vehicles.
2. Use tire stops under the tires to prevent the vehicle from moving.

When the vehicle is parked in snow or when it snows, raise the wiper blades off the glass to prevent damage to them.

When the vehicle has been left parked after use on roads heavily covered with snow, or has been left parked during a snowstorm, icing may develop on the brake system, which could cause poor braking action. Check for snow buildup or ice on the suspension, disc brakes and brake hoses underneath the vehicle.

If there is caked snow or ice, remove it, being careful not to damage the disc brakes and brake hoses and ABS harness.

### ▼ Refueling in cold weather

To help prevent moisture from forming in the fuel system and the risk of its freezing, use of an antifreeze additive in the fuel tank is recommended during cold weather.

Use only additives that are specifically designed for this purpose. When an antifreeze additive is used, its effect lasts longer if the tank is refilled whenever the fuel level reaches half empty.

If your SUBARU is not going to be used for an extended period, it is best to have the fuel tank filled to capacity.

### ■ Driving on snowy and icy roads



#### **WARNING**

**Do not use the cruise control on slippery roads such as snowy or icy roads. This may cause loss of vehicle control.**

To prevent skidding and slipping, avoid sudden braking, abrupt acceleration, high-speed driving, and sharp turning when driving on snowy or icy roads.

Always maintain ample distance between your vehicle and the vehicle ahead of you to avoid the need for sudden braking.

Use the engine brake effectively to control the vehicle speed. (Shift into a lower gear when necessary.)

Avoid locking the front wheels because that can lead to a loss of steering control. When braking with a vehicle not equipped with an Anti-Lock Brake System (ABS), press the brake pedal repeatedly at short intervals to prevent the wheels from locking. Then apply the brakes softly to bring the vehicle to a stop.

An Anti-Lock Brake System (ABS) enhances your vehicle's braking performance on snowy and icy roads. Refer to ABS (Anti-Lock Brake System) in this chapter for information on braking on slippery surfaces in ABS equipped vehicle.

### ▼ Wiper operation when snowing

Before driving in cold weather, make sure the wiper blades are not frozen to the windshield or rear window. If the wiper blades are frozen

---

to the windshield or rear window, use the defroster with the airflow control dial in the “” position and the temperature control dial turned fully to the right until the wiper blades are completely thawed out. To thaw out the rear wiper blade, use the rear window defogger.

When driving in snow, if frozen snow starts to stick on the surface of the windshield despite wiper operation, use the defroster with the airflow control dial in “” and the temperature control dial turned fully to the right. After the windshield gets warmed enough to melt the frozen snow on it, wash it away using the windshield washer.

Snow stuck on the wiper arm prevents the wiper from working effectively. If snow is stuck on the wiper arm, pull off the road to a safe place, then remove it. If you stop the car at the side of the road, use the hazard warning flasher to alert other drivers.

We recommend use of non-freezing type wiper blades during the seasons you could have snow falling and sub-zero temperature.

## ■ Snow tires

### **WARNING**

- **When replacing a tire, make sure you use only the same size, construction, brand, and load range as the original tires listed on the tire placard. Using other sizes or construction may result in severe mechanical damage to the drive train of your vehicle and may affect ride, handling, braking, speedometer/odometer calibration, and clearance between the body and tires. It also may be dangerous and lead to loss of vehicle control.**
- **Do not use a combination of radial, belted bias or bias tires since it may cause dangerous handling characteristics and lead to an accident.**

Your vehicle is equipped with “all season tires” which are designed to provide an adequate measure of traction, handling and braking performance in year-round driving. In winter, it may be possible to enhance performance through use of tires designed specifically for winter driving conditions.

If you choose to install winter tires on your vehicle, be sure to use the



same tire size, construction, brand, and load range as the original tires. The recommended tire sizes and pressure are provided on the tire label, which can be found on the driver's side door jamb under the latch.

Remember to drive with care at all times regardless of the type of tires on your vehicle.

### ■ Tire chains



#### **CAUTION**

**Tire chains cannot be fitted with P205/60R15 tires for OUTBACK and P205/55R16 tires for RS because of lack of clearance between the tire and body.**

Driving on snowy grades or icy roads may require the use of tire chains, in which case put the chains on the front wheels only. Use only SAE class S type chains that are of the correct size for your tires so as not to damage the vehicle body or suspension.

When driving with tire chains, drive at speeds below 19 mph (30 km/h).

When a temporary spare tire is on a front wheel, replace the temporary spare tire with the rear tire on the same side of the vehicle, and then fit chains on the front tires.

Always use the utmost care when driving with tire chains — overconfidence because you are driving with tire chains could easily lead to a serious accident.

### ■ Rocking the vehicle

If you must rock the vehicle to free it from snow, sand, or mud, depress the accelerator pedal slightly and move the selector lever back and forth between “D” and “R” repeatedly. Do not race the engine. For the best possible traction, avoid spinning the wheels when trying to free the vehicle.

When the road surface is extremely slippery, you can obtain better traction by starting the vehicle with the transmission in 2nd than 1st (both for MT and AT).

Refer to the Automatic Transmission section in this chapter for information on holding the transmission in 2nd position.

– **CONTINUED**–

---

## ■ Corrosion protection

Refer to the Corrosion Protection section (chapter 9).

---

## Loading your vehicle

---

### **WARNING**

- Never allow passengers to ride on the folded rear seatback in the trunk or in the cargo area. Doing so may result in serious injury.
- Never stack luggage or other cargo higher than the top of the seatback because it could tumble forward and injure passengers in the event of a sudden stop or accident. Keep luggage or cargo low, as close to the floor as possible.
- When you carry something inside the vehicle, secure it whenever you can to prevent it from being thrown around inside the vehicle during sudden stops, sharp turns or in an accident.
- Do not pile heavy loads on the roof. These loads raise the vehicle's center of gravity and make it more prone to tip over.
- Secure skis and other lengthy items properly to prevent them from shooting forward and causing serious injury during a sudden stop.
- Never exceed the maximum load limit. If you do, some parts on your vehicle can break, or it can change the way your vehicle handles. This could result in loss of control and cause personal injury. Also, overloading can shorten the life of your vehicle.
- Do not place anything on the rear shelf behind the rear seatback (for sedan) or the extended luggage cover (for wagon). Such items could tumble forward in the event of a sudden stop or a collision. This could cause serious injury.

### **CAUTION**

Do not carry spray cans, containers with flammable or corrosive liquids or any other dangerous items inside the vehicle.

## ■ Vehicle capacity weight

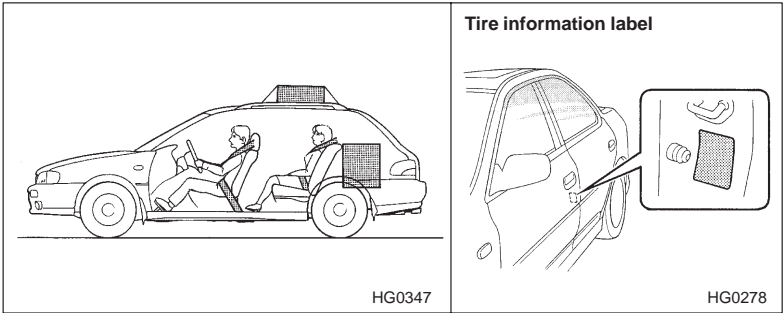

The load capacity of your vehicle is determined by weight, not by available cargo space. The maximum load you can carry in your vehicle is shown as the Vehicle Capacity Weight on the tire information label attached to the driver's side door jamb. It includes the total weight of driver and all passengers and their belongings, any optional equipment such as a trailer hitch, roof rack or bike carrier, etc., and the tongue load of a trailer.

## ■ GVWR and GAWR (Gross Vehicle Weight Rating and Gross Axle Weight Rating)

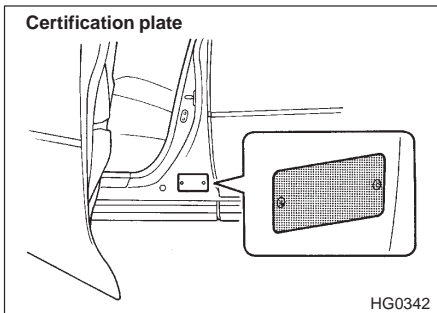

The certification plate attached to the driver's side door jamb shows GVWR (Gross Vehicle Weight Rating) and GAWR (Gross Axle Weight Rating).

– CONTINUED –

---

Rating).

The GVW (Gross Vehicle Weight) must never exceed the GVWR. GAW is the combined total of weight of the vehicle, fuel, driver, all passengers, luggage, any optional equipment and trailer tongue load. Therefore, the GVW changes depending on the situation. The GVWR equals Curb Weight (actual weight of your vehicle – including standard equipment, fluids, emergency tools and spare tire assembly) plus the vehicle capacity weight.

In addition, the total weight applied to each axle (GAW) must never exceed the GVWR. The front and rear GAWs can be adjusted by relocating luggage inside the vehicle.

Even if the total weight of your luggage is lower than the vehicle capacity weight, either front or rear GAW may exceed the GAWR, depending on the distribution of the luggage.

If you carry heavy loads in the vehicle, you should confirm that GVW and front and rear GAWs are within the GVWR and GAWR by putting your vehicle on a vehicle scale, found at a commercial weighing station.

Do not use replacement tires with a lower load range than the originals because they may lower the GVWR and GAWR limitations. Replacement tires with a higher load range than the originals do not increase the GVWR and GAWR limitations.

#### **NOTE**

For better fuel economy, do not carry unneeded cargo.

## **Trailer towing**

---

Your car is designed and intended to be used primarily as a passenger-carrying vehicle. Towing a trailer puts additional loads on your car's engine, drive train, brakes, tires and suspension and has an adverse effect on fuel economy.

If you do decide to tow a trailer, your safety and satisfaction depend upon proper use of correct equipment and cautious operation of your vehicle. Seek the advice of a professional trailer and/or hitch supplier to assist you in purchasing a hitch and other necessary towing equipment

appropriate for your vehicle. In addition, be sure to follow the instructions on correct installation and use provided by the trailer and other towing equipment manufacturers.

SUBARU assumes no responsibility for injuries or vehicle damage that result from trailer towing equipment, or from any errors or omissions in the instructions accompanying such equipment or for your failure to follow the proper instructions.

### ■ **Warranties and maintenance**

SUBARU warranties do not apply to vehicle damage or malfunction caused by trailer towing. If you use your vehicle to tow a trailer, more frequent maintenance will be required due to the additional load.

Under no circumstances should a trailer be towed with a new vehicle or a vehicle with any new power train component (engine, transmission, differential, wheel bearings, etc.) for the first 1,000 miles (1,600 km) of driving.

### ■ **Maximum load limits**



#### **CAUTION**

**Never exceed the maximum load limits explained below. Exceeding the maximum load limits could cause personal injury and/or vehicle damage.**

The total trailer weight (trailer weight plus its cargo weight) with brakes must never exceed 1,500 lbs (681 kg).

The Gross Vehicle Weight (i.e., the combined weight of vehicle, driver, passengers, luggage, trailer hitch, trailer tongue load and any other optional equipment installed on your vehicle) must never exceed the Gross Vehicle Weight Rating (GVWR). GVWR is shown on the certification plate located on the left center pillar of your vehicle.

The total weight applied to each axle must never exceed the Gross Axle Weight Rating (GAWR). The front and rear GAWR are also shown on the certification plate.

The maximum trailer tongue load must never exceed 150 lbs. (68 kg).

**– CONTINUED–**

---

The tongue load can be adjusted by proper distribution of the load in the trailer. Never load the trailer with more weight in the back than the front; approximately 60 percent of the trailer load should be in the front and approximately 40 percent in the rear. Also, distribute the load as evenly as possible on both the left and right sides.

To check both GVWR and GAWR and to confirm that the total weight and weight distribution are within safe driving limits, you should have your vehicle and trailer weighed at a commercial weighing station.

Be sure that all cargo is firmly secured to prevent a change in weight distribution while driving.

### ■ Trailer hitches



#### **WARNING**

**Never drill the frame or under-body of your vehicle to install a commercial trailer hitch. If you do, dangerous exhaust gas, water or mud may enter into the passenger compartment through the drilled hole. Exhaust gas contains carbon monoxide, a colorless and odorless gas which is dangerous, or even lethal, if inhaled. Also, drilling the frame or under-body of your vehicle could cause deterioration of strength of your vehicle and cause corrosion around the drilled hole.**



#### **CAUTION**

- **Do not modify the vehicle exhaust system, brake system, or other system when installing a hitch or other trailer towing equipment.**
- **Adequate size trailer brakes are required when the trailer and its cargo exceed 700 lbs (318 kg) total weight.**

Choose a proper hitch for your vehicle and trailer. SUBARU does not offer accessory trailer hitches. Consult with a professional hitch supplier to assist you in choosing an appropriate hitch for your vehicle. Be sure to follow all of the hitch manufacturer's instructions for installation and use.

## ■ Trailer lights



### **CAUTION**

**Direct splicing or other improper connection may damage your vehicle's electrical system and cause a malfunction of your vehicle lighting system.**

Consult your authorized SUBARU dealer concerning the connection of wires for trailer lights. Check for correct operation of the turn signals and brake lights each time you hitch up.

## ■ Side mirrors

After hitching a trailer to your vehicle, check that the standard side mirrors provide a good rearward field of view without significant blind spots. If significant blind spots occur with the vehicle's standard side mirrors, use towing mirrors that conform with Federal, state/province and/or other applicable regulations.

## ■ Tires



### **WARNING**

**Never tow a trailer when the temporary spare tire is used. The temporary spare tire is not designed to sustain the towing load. Use of the temporary spare tire when towing can result in failure of the spare tire and/or less stability of the vehicle and may lead to an accident.**

Make sure that all the tires on your vehicle are inflated to the pressure specified on the tire placard located on the left center pillar of your vehicle.

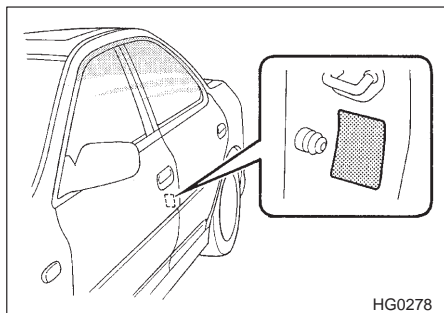

Trailer tire condition, size, load rating and proper inflation pressure should be in accordance with the trailer and tire manufacturer's specifications.

In the event your vehicle gets a flat tire when towing a trailer, ask a commercial road service to repair the flat tire.

If you carry a regular size spare tire in your vehicle or trailer as a precaution against getting a flat tire, be sure that the spare tire is firmly secured.

### ■ Trailer towing tips

When towing a trailer, steering, stability, stopping distance and braking performance will vary from normal operation. For safety's sake, you should employ extra caution when towing a trailer and you should never speed.

You should also keep the following tips in mind:

Sufficient time should be taken to learn the "feel" of the vehicle/trailer combination before starting out on a trip. In an area free of traffic, practice turning, stopping and backing up.

You should allow for considerably more stopping distance when towing a trailer. Avoid sudden braking because it may result in skidding or jack-knifing and loss of control.

Avoid abrupt starts and sudden accelerations. If your vehicle has a manual transmission, always start out in 1st gear and release the clutch



at moderate engine rpm.

Avoid uneven steering, sharp turns and rapid lane changes.

Slow down before turning. Make a longer than normal turning radius because the trailer wheels will be closer than the vehicle wheels to the inside of the turn. In a tight turn, the trailer could hit your vehicle.

Crosswinds will adversely affect the handling of your vehicle and trailer, causing sway. Crosswinds can be due to weather conditions or the passing of large trucks or buses. If swaying occurs, firmly grip the steering wheel and immediately slow down gradually.

When passing other vehicles, considerable distance is required because of the added weight and length caused by attaching a trailer to your vehicle.

Before going down a steep hill, slow down and shift into low gear in order to utilize the engine braking effect and prevent overheating of your vehicle's brakes. Do not make sudden downshifts.

When going uphill on hot days, turn off your air conditioner to reduce the possibility of engine overheating caused by the added load of the trailer. Pay attention to your water temperature gauge.

If your vehicle has an automatic transmission, avoid using the accelerator pedal to stay stationary on an uphill slope instead of using the parking brake or foot brake. This may cause the transmission fluid to overheat.

Always block the wheels under both vehicle and trailer when parking. Apply the parking brake firmly. You should not park on a hill or slope. But if parking on a hill or slope cannot be avoided, you should take the following steps:

1. Apply the brakes and hold the pedal down.
2. Have someone place wheel blocks under both the vehicle and trailer wheels.
3. When the wheel blocks are in place, release the regular brakes slowly until the blocks absorb the load.
4. Apply the regular brakes and then apply the parking brake; slowly re-

**– CONTINUED–**

---

lease the regular brakes.

5. Shift into 1st or reverse gear (manual transmission) or “P” (automatic transmission) and shut off the engine.

If the ABS warning light illuminates while the vehicle is in motion, stop towing the trailer and have repairs carried out immediately by the nearest SUBARU dealer.